

TIRE RACK INSTALLATION INSTRUCTIONS

COMPONENT PARTS

 <p>AU / HAU (Height in Feet) STD/HVY ANGLE UPRIGHT</p>	<p>Hgt Sgl Entry / Dbl Entry 60" = 2 TIERS / 4 TIERS 84" = 3 TIERS / 6 TIERS 120" = 4 TIERS / 8 TIERS 144" = 5 TIERS / 10 TIERS 180" = 6 TIERS / 12 TIERS</p> <p><small>TIRES VARY IN SIZE, ALLOW 3-6 INCHES MORE THAN TIRE SIZE TO ALLOW FOR EASE OF USE.</small></p>	 <p>WT WALL TIE 9" or BT BACK TIE 18" All Tire Racks over 60" High Must Be Anchored To A Wall or Another Unit To Avoid Tipping! (Wall Anchors provided by installer)</p>
 <p>TU/HTU (Height in Feet) STD/HVY "T" UPRIGHT</p>	 <p>TDR (Length in Inches) TIRE DBL RIVET BEAM</p>	 <p>SB - SWAY BRACE 12" 30" Between Braces / One Hole up from TDR</p>

STEP 1 OF 3 - ASSEMBLE UPRIGHT ENDS

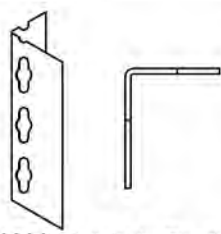
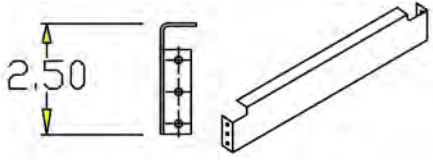
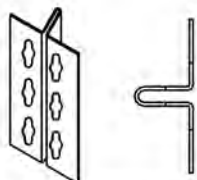
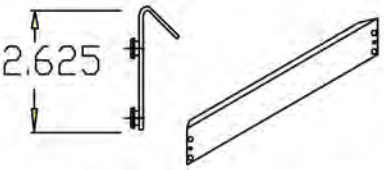
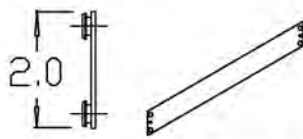
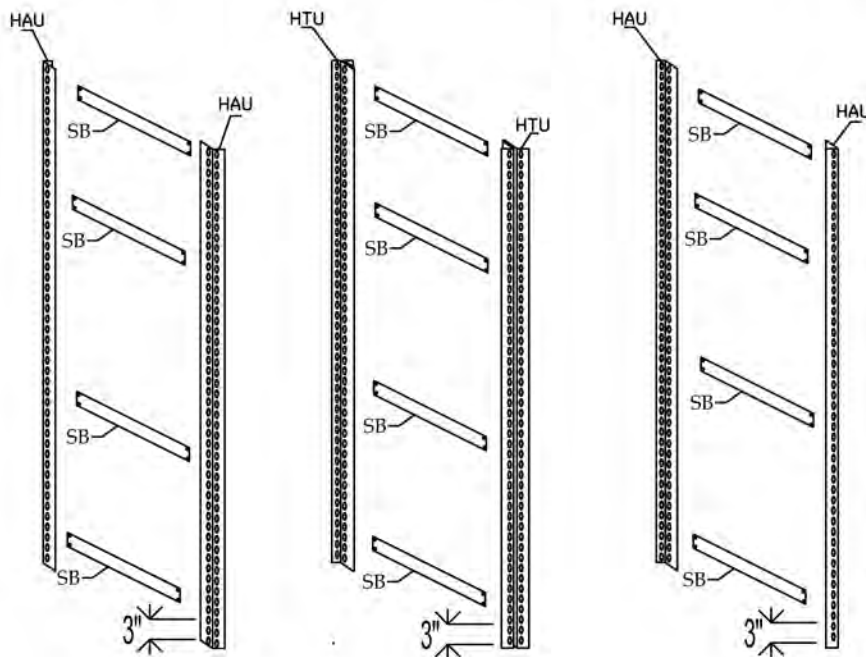

NOTE:
 # OF SBs
 (Per 2 Uprights)
 IS EQUAL TO
 # OF TIERS +1.
 PLACE SBs TWO
 HOLES HIGHER
 THAN THE TIER
 BEAM.

INSTALL TOP BRACE IN TOP HOLES,
 BOTTOM BRACE 3" OR TWO HOLES UP FROM BOTTOM,
 SPACING SHOULD BE APROX. 30" APART ON 1.5" CENTERS

ASSEMBLY SHOWS STARTER ANGLES (HAU)
 AND ADDER INTERMEDIATE (HTU).

STEP 2 OF 3: INSTALL THE TIRE RACK BEAMS (TDR)
 SPACING IS APPROXIMATELY 30" BETWEEN TIERS

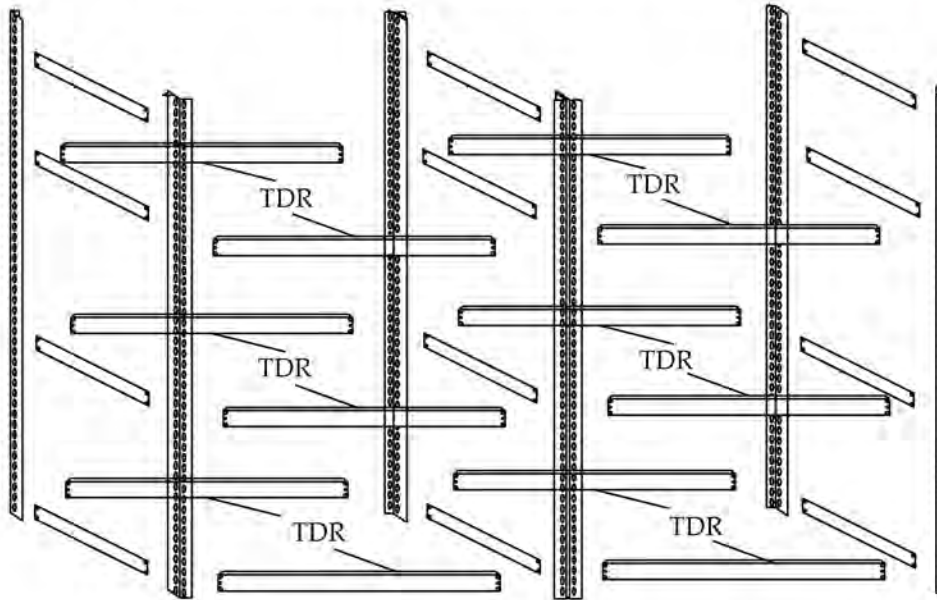

**STEP 3 OF 3 - ATTACH BACK TO BACK UNITS
 - OR ATTACH TO WALL**

ANY TIRE RACK OVER 60" IS A TIP RISK AND **MUST** BE ANCHORED TO ANOTHER UNIT OR TO A WALL TO PREVENT TIPPING

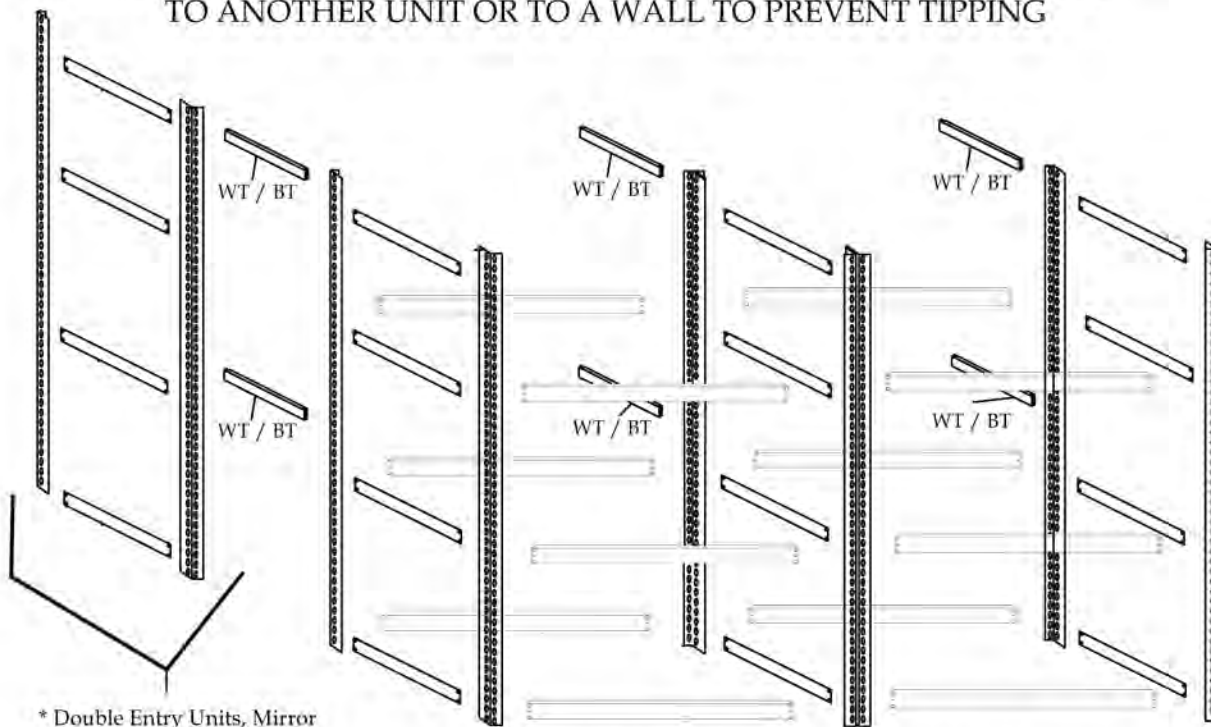

* Double Entry Units, Mirror The Single Entry.

* Units **MUST** be Secured To Another Unit or Wall, Using Wall or Back Ties. (Anchors not Included)

USE TWO WT/BT PER UPRIGHT END.
 PLACE AT TOP AND MID POINT OF UPRIGHTS. UNITS WITH MORE THAN 5 TIERS USE THREE WT/BT PER UPRIGHT END.